

AIR-021

AI Inference System Based on NVIDIA® Jetson Orin™ NX/ Orin™ Nano



Features

- Compact and high performance AI box up to 157 TOPS AI computing
- NVIDIA® Jetson Orin NX 16GB/8GB and Orin Nano 8GB Modules
- 12-24V wide power and -20-50 °C (NX) -10-50°C (NANO) supported
- Multiple IO ports: LAN, DIO, COM, CANBus, USB 3.2
- Versatile expansions with M.2 B/E/M key/SD card support
- Support Linux Ubuntu OS 22.04 and JetPack 6.2 SDK
- Support Edge AI SDK / Inference Kit: Designed for performance-optimized, multi-model edge AI applications.



Specifications

Model		AIR-0210-S0A1U	AIR-0210-B0A1U*	AIR-021R-S7A1U
Platform		Orin™ NX 16GB	Orin™ NX 8GB	Orin™ Nano 8GB
Processor System	CPU	8-Core ARM® Cortex®-A78AE v8.2	6-Core ARM® Cortex®-A78AE v8.2	6-Core ARM® Cortex®-A78AE v8.2
	GPU	1024-core NVIDIA Ampere architecture GPU with 32 Tensor Cores		
	AI Performance Reference	157 TOPS (Super Mode)	117 TOPS (Super Mode)	67 TOPS (Super Mode)
	Memory	16GB 128-bit LPDDR5	8GB 128-bit LPDDR5	8GB 128-bit LPDDR5
Ethernet	Interface	RJ-45		
	Controller	Realtek 8111 & Intel® i226		
	Speed	LAN1 1GbE / LAN2 2.5GbE		
Display	HDMI	1 x HDMI 2.1 TMDS (Max. resolution 3840 x 2160 @ 60Hz for NX, 30Hz for NANO)		
IO Ports	USB	4 x USB 3.2 Gen2 Type A 1 x USB Type C (Only recovery mode)		
	CANBus	1 x DB9 (1 Mbps)		
	GPIO	1 x 8 bit		
	COM	2 x RS232/422/485, 4wire		
	Switch	AT/ATX mode and recovery mode switch		
TPM		IC NPCT764AAEYX TPM2.0		
Expansion	M.2 B Key	1 x M.2 3052 (USB3.2 Gen2) for 5G module with Nano SIM holder		
	M.2 E Key	1 x M.2 2230 (PCIe x1/USB2.0) for WIFI/BT		
	Micro SD	1 x (USB 2.0, not support boot up by MicroSD)		
Storage	M.2 M Key	1 x M.2 2280 (PCIex4), 1x M.2 2242 (PCIe x1)		
Power Requirement	Power Supply	12-24V DC-IN, Power adaptor 120W		
	Power Type	Optional ATX/AT mode, ATX default		
Power Consumption	Typical (OS idle mode)	13.36W	12.35W	12.93W
	Max. (Full loading)	46.92W	25.19W	31.6W
Environment	Operational Temperature	Fanbased: -20-50 °C w/o airflow (NX 16G) Fanless: -20-50 °C w/0.7 m/s airflow (NX 8G) & -10-50 °C w/0.7 m/s airflow(NANO 8G)		
	Operating Humidity	95% @ 40 °C (non-condensing)		
	Vibration	3 Grms @ 5 ~ 500 Hz, random, 1 hr/axis		
Mechanical	Dimensions (W x D x H)	138 x 110 x 57 mm		
	Weight	1.2 kg		
	Mounting Support	Wall mount/Din rail		
Operating System	Linux	Ubuntu 22.04 LTS with JetPack 6.2		
Software Support	Software API	Edge AI SDK compatible		
Certifications	EMC/Safety	CE/FCC Class B, CB, UL, CCC and BSMI (No RED Certificate)		

*Limited to 20W TDP

Dimensions

Unit: mm [inch]

Orin NX 16G (Fanbased)

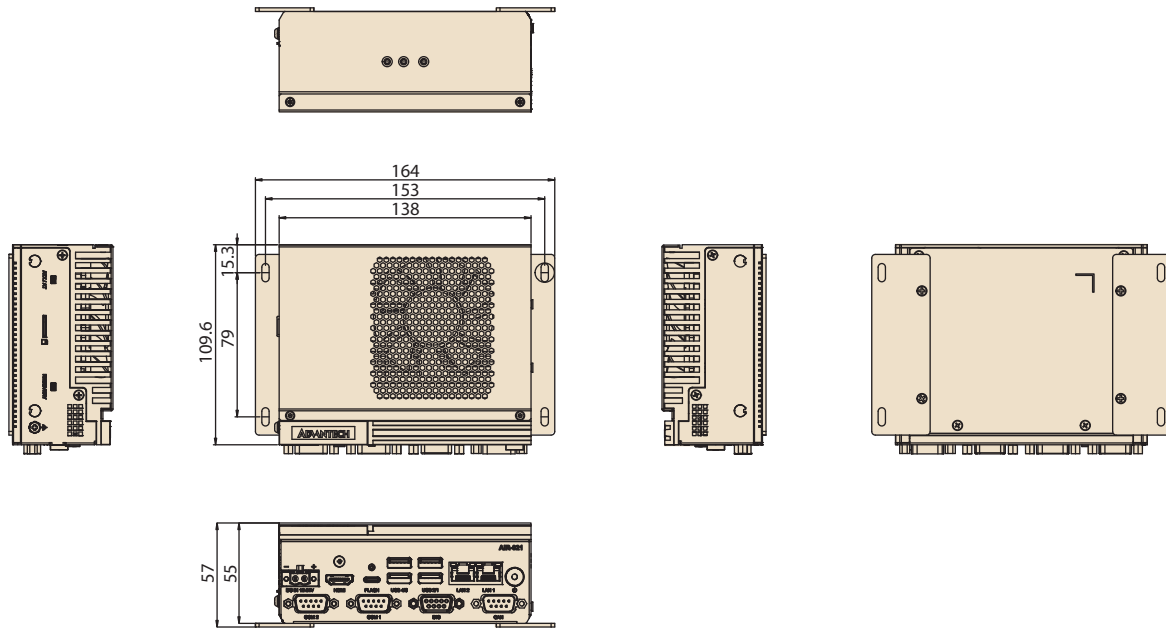

Orin NX 8G/Orin NANO 8G (Fanless)

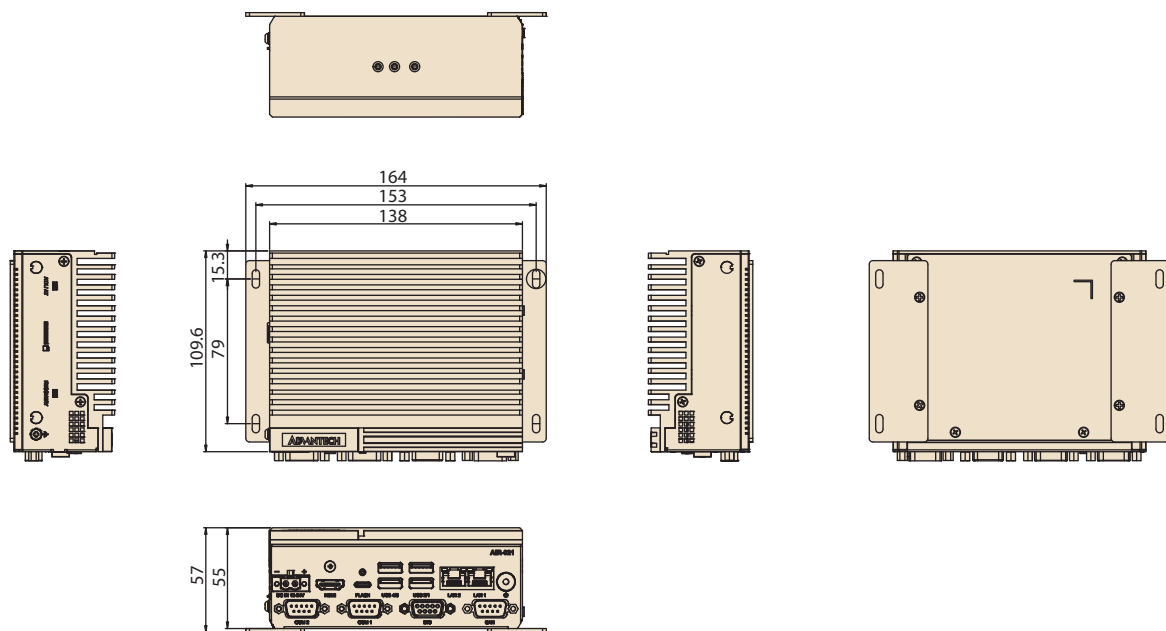

Front Panel I/O Mechanical Layout

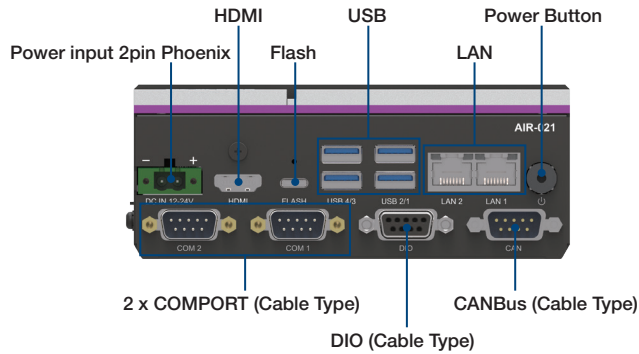

Side Panel I/O Mechanical Layout

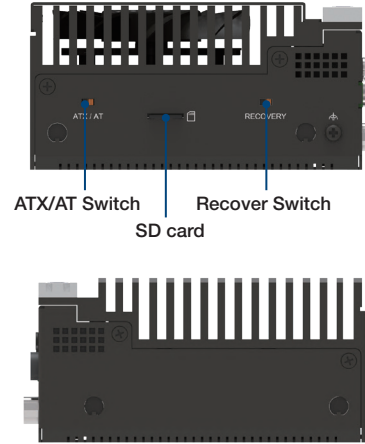

Din-rail

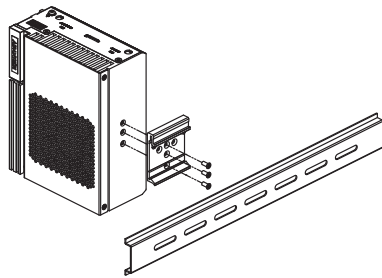

Wall-mount

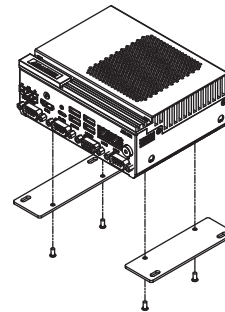

Ordering Information

Part No.	Thermal solution	NVIDIA Module	NVIDIA Module Memory	NVIDIA Module eMMC	Storage	HDMI	GbE	USB	CANBus	RS-232/422/485	GPIO	Power input	Operating Temperature
AIR-0210-S0A1U	Fanbased	Orin NX	16GB LPDDR5	N/A	M.2 M.Key 2242/2280 (default only built-in 128GB in M.2 2280)	1	2	4	1	2	1	12-24V _{oc}	-20~50 °C
AIR-0210-B0A1U	Fanless	Orin NX	8GB LPDDR5	N/A									-20~50 °C
AIR-021R-S7A1U	Fanless	Orin Nano											-10~50 °C

*The system OS will be pre-installed in a 128GB NVMe M.2 SSD.

Packing List

Part Number	Description	Quantity
AIR-021	NVIDIA AI Inference System	1
1652000099	Phoenix connector counterpart	1
1700034631-01	M cable USB-A 4P(M)/USB-C 24P(M) 90cm	1
-	Simplified Chinese User Manual	1
-	Wall Mount Kit for AIR-021	1
-	Thermal-Pad kit (M.2 2242 storage & 3052 5G module)	1

Optional

Part Number	Description
96PSA-A120W24T2-4	Power Adapter 24V 120W
1702002600	Power Cord UL 3P 10A 125V 183cm (US)
1702002605	Power Cord EU 3P 10A 250V 183cm (EU)
1702031801-11	Power Cord BSI 3P 10A 250V 183cm (UK)
1700000237	Power Cord PSE 3P 12A 125V 183cm (Japan)
1700013977	Power Cord CCC 3P 10A 250V 200cm 90° (China)
1960015198T011	Din Rail Kit for AIR-021
AIW-170BQ-001	Qualcomm Wifi6E M.2 2230 E-Key
1751000622-01	1x Cable Ant. L150mm for WIFI
1751000651-01	1x Antenna for WIFI
AIW-356DQ-E01	Qualcomm 5G M.2 3052 B-Key
1751000625-01	1x Cable Ant. L150mm for 5G
1750009372-01	1x Antenna for 5G

Note: If Wi-Fi/5G module is required, the package must include the module, antenna, and antenna cable

Advantech SUSI is a device management and system monitoring suite for hardware configuration, control, and status monitoring. SUSI information: <https://github.com/ADVANTECH-Corp/SUSI>

Inference Kit | Production-Ready AI Inference on Edge Devices

Provides a unified and hardware-aligned runtime for deploying and validating AI inference on edge devices

It simplifies integration across CPUs, GPUs, and AI accelerators while enabling performance benchmarking and compatibility verification on target hardware. Designed for production use, Inference Kit helps hardware partners ensure stable, scalable, and repeatable AI deployment across product lines.

ADANTECH

Edge AI SDK Inference Kit

Streamlined Edge Inference

- Ready-to-Run Inference Runtime
- Accelerator-Aware Optimization
- Stable Edge Production Stack
- Unified Inference Interfaces

Benefits and Features



Unified Inference Runtime

- Consistent inference across CPUs, GPUs, and accelerators
- Vendor-optimized runtime integration
- Built-in UniInfra acceleration framework
- Optimized inference pipelines and runtime efficiency



Hardware Validation

- Benchmarking on target devices
- OS and accelerator compatibility validation
- Performance and stability verification



Production-Ready Deployment

- Stable, long-running inference operation
- System monitoring and observability support
- Designed for scalable edge deployment



Global Customer Support

- System reliability certification
- Inference computing enablement
- Edge-to-cloud scalability collaboration

