

STEVIE™ Carrier for AGX Xavier

Low cost, high performance carrier for NVIDIA Jetson AGX Xavier modules

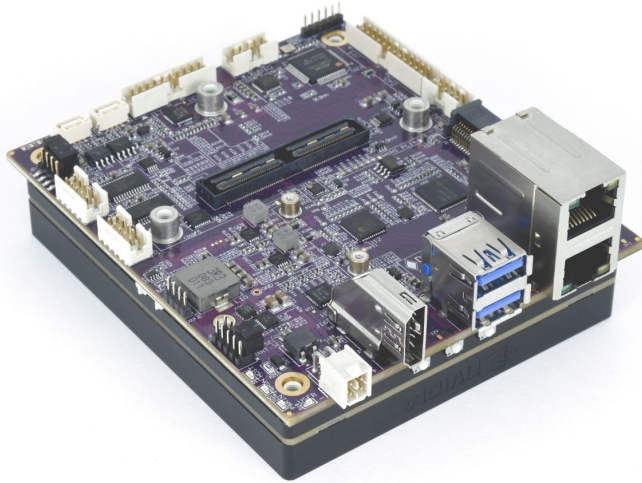

FEATURES

- Size: Size: 3.5" x 4.00" / 92mm x 105mm
- Input voltage 9-20VDC

On-board features:

- I/O breakout from Xavier board:
 - 2x USB 3.1
 - 2x USB 2.0
 - 2x Gigabit Ethernet
 - 2x HDMI
 - 4x RS-232/RS485/RS422
 - 2x CAN
 - Audio
 - SAM DAQ circuit: 6xADC input to SAM controller and 2x DAC via SAM controller
 - Digital IOs: 13 Digital IO via SAM controller

Socketed features:

- Camera module connector with 4x4 CSI lanes supporting up to 8x 2-lane CSI cameras
- UFS flash socket + Micro SD
- M.2 PCIe x4 socket (2280 size)
- 1mPCIe socket

STEVIE offers a compact, low-cost, feature-packed carrier board solution for the NVIDIA Jetson AGX Xavier computer module. STEVIE measures 92 x 105mm (~ 3.5 x 4.0"), just slightly larger than the AGX Xavier module (87 x 100mm). This small outline enables Stevie to provide the maximum amount of I/O and support full-size 2280 M.2 modules in the smallest possible size.

STEVIE utilizes the NVIDIA Jetson AGX Xavier embedded computer module to deliver unmatched performance for AI, machine learning, image processing, and other compute-intensive tasks. The Xavier module delivers up to 30 TeraOps in performance (3×10^{13} operations per second) at a maximum power dissipation of 30 watts. Xavier also offers scalable performance for applications requiring lower overall power consumption of 10 or 15 watts. The module runs at 32 TOPs on a 512-core Volta GPU with Tensor Cores and accelerators, enabling high-performance AI-powered autonomous

machines like never before. At 87 x 100mm (3.4 x 3.9") it is slightly bigger than the other Jetson modules.

The most popular I/O is located along the front edge of the board using commercial style panel I/O connectors. This facilitates installation in an enclosure with fewer internal cables, helping to further reduce overall system cost and size.

PCIe Minicard and M.2 sockets enable the installation of flashdisk and I/O expansion module to customize Stevie to your particular application requirements.

STEVIE is ideal for NVIDIA Jetson Xavier applications in typical commercial / industrial environments requiring low cost and compact size. For mobile and outdoor applications requiring a higher degree of ruggedness or more advanced I/O, see our **ELTON** carrier with PCIe/104 I/O expansion.

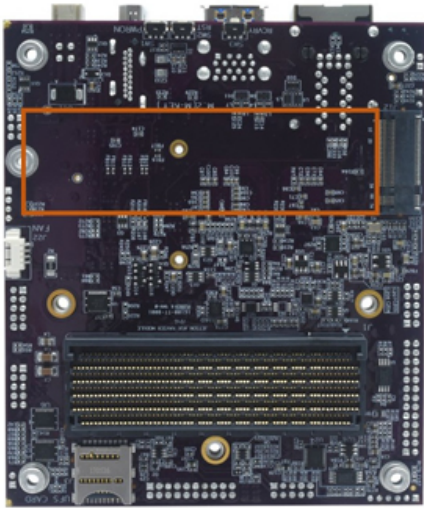

Bottom view of STEVIE showing the M.2 2280 socket (outlined).

Stevie is available as a complete system, with the AGX Xavier 32GB module installed and preprogrammed with Diamond's customized Linux OS for Jetson, all assembled into a sturdy steel and aluminum enclosure. The enclosure provides access to all the front edge I/O connectors plus 4 additional DB9 connectors (serial ports and/or CAN), the second HDMI port, 2 USB 2.0 ports, and up to two SMA type antenna connectors for an installed M.2 or Minicard module. To learn more about these systems [click here](#).



 Stevie Block Diagram

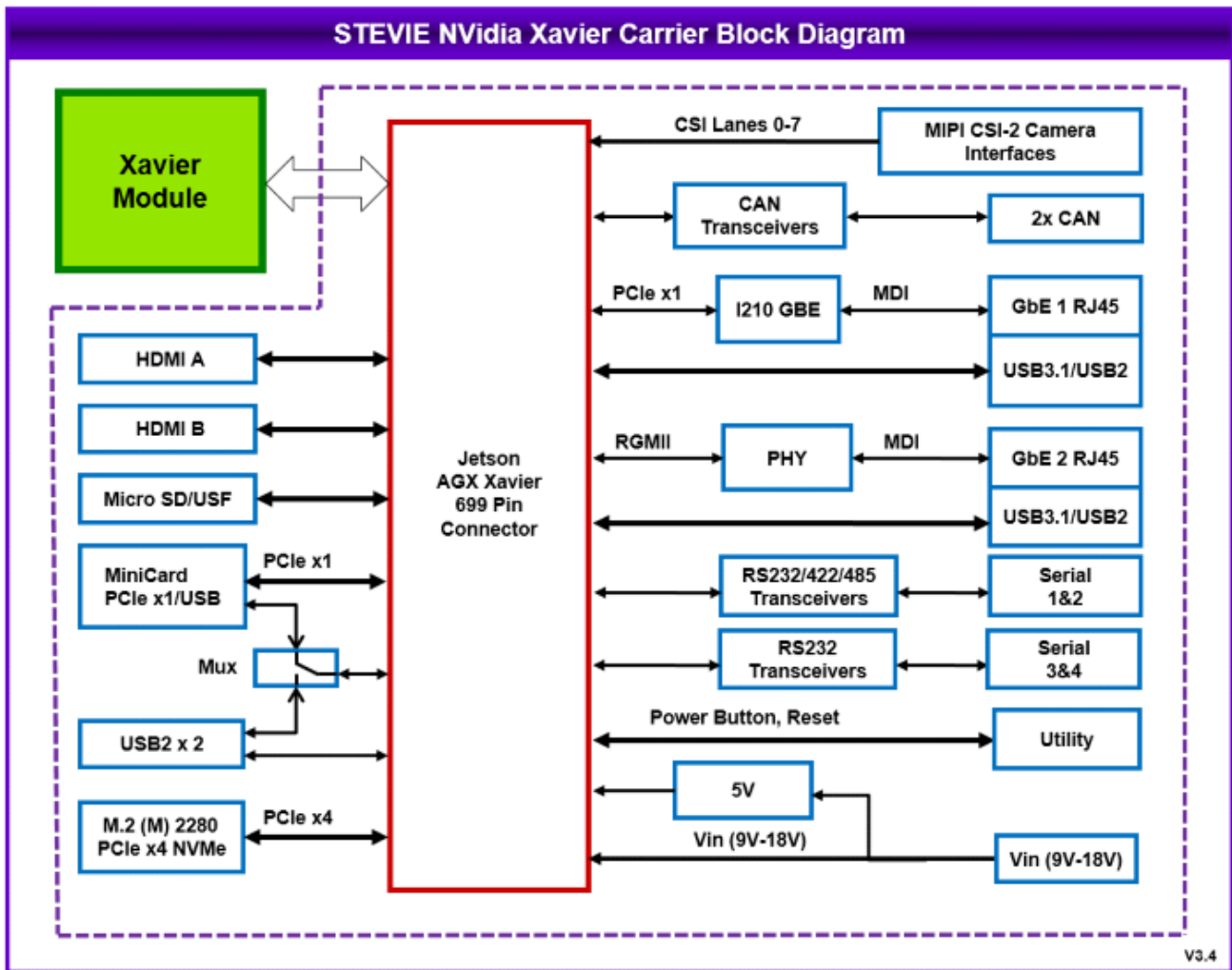

◆ Data Acquisition

A built-in data acquisition circuit provides 12-bit A/D up to 1MSPS, 12-bit D/A, and 3.3V GPIO. Diamond's free C-language programming library simplifies application development, while a GUI control panel offers convenient control and monitoring of real-world processes as well as ready-to-run data logging capability.

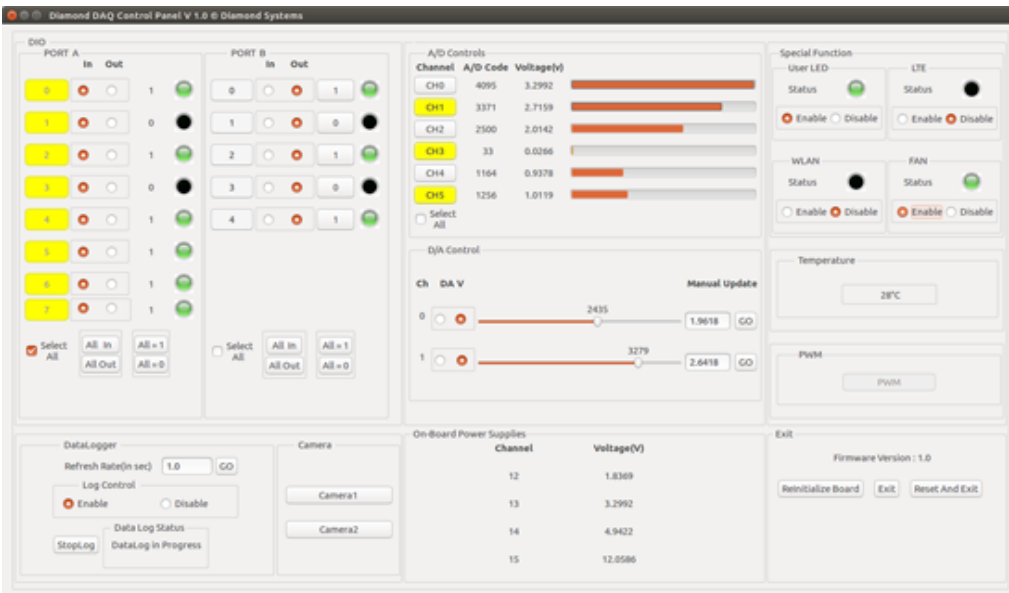

◆ Stevie Cable Kit

The cables in this cable kit are not sold separately.

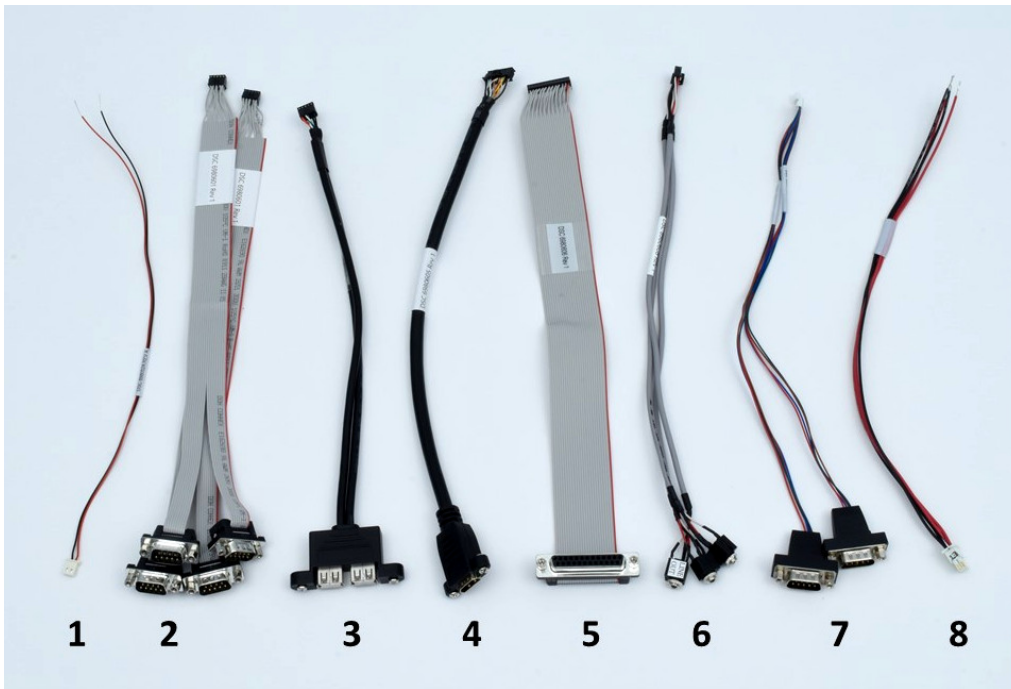

CK-STV-01 includes the following cables:

No.	Qty	Cable	Description	Drawing
1	1	6980524	Cable, External Battery, Molex Spox	Show
2	2	6980601	Dual serial, latching, 2x DB9M	Show
3	1	6980602	Cable, Dual USB 2.0, FCI 98414 to D	Show
4	1	6980605	HDMI Cable	Show
5	1	6980606	DAQ Cable	Show
6	1	6980608	Audio cable 2mm to 3x3.5mm	Show
7	2	6981182	CANbus 2.0 dual port cable	Show
8	1	6981507	Power Cable, IPD 2x2 to Leads, 20AV	Show

◆ Models and Accessories

STEVE™ Carrier for AGX Xavier

available models:

STV-BB01 STEVIE carrier board for Jetson AGX Xavier computer module

Please login or signup for an online quote request.

Cables and accessories

available models:

CK-STV-01 CK-STV-01 cable kit

Please login or signup for an online quote request.