

FLOYD Carrier for Nano & Xavier NX

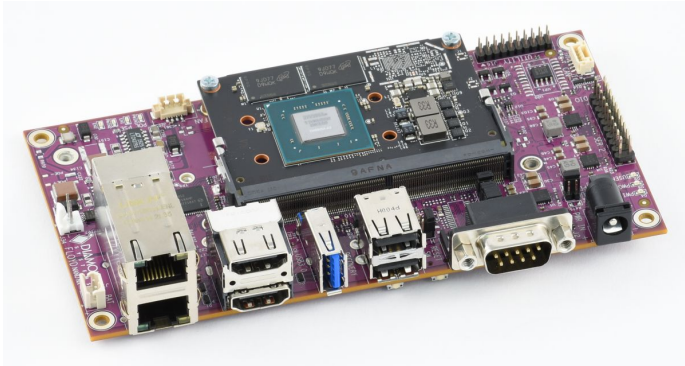

Converts Jetson Nano and Xavier NX into complete embedded systems



Floyd model BB01 with Nano module installed

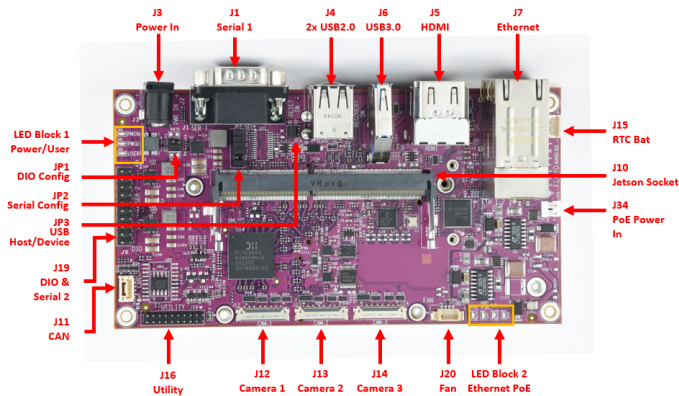

Floyd top side features

FEATURES

- 1 or 2 gigabit Ethernet ports
- Optional PoE+ support (with external power source)
- 2 HDMI 2.0a/b ports
- 1 USB 3.0 port with type A connector
- 2 USB 2.0 ports with type A connector; 1 port can serve as OTG
- 8 GPIO with 3.3V logic levels
- 2 serial ports with RS-232/422/485 (depending on model)
- 3 dual/quad lane MIPI/CSI camera ports
- 1 CAN port (NX module only)
- 1 Mini PCIe socket with PCIe and USB support
- 1 M.2 2280 PCIe x1 or x4 NVME socket
- Size: 5.8 x 3.0" / 147 x 76mm
- Input voltage: 12-24VDC
- -25 to +80°C operating temperature (same as Jetson Nano / NX)

The FLOYD carrier board converts the Nvidia Jetson Nano and Xavier NX modules into complete embedded systems by providing interface circuitry, I/O connectors for all module features, camera interfaces, power supply, and additional I/O. Camera inputs include 2 PoE Gigabit Ethernet ports, 3 MIPI/CSI 2/4-lane connectors, and 1 USB 3.0 port. MiniCard, M.2, and Micro SD sockets support I/O expansion and storage. FLOYD + NVIDIA redefine possibility; the combination of Nvidia's performance/power efficiency and Diamond's I/O enables a new generation of high-compute, low-cost solutions.

Floyd's multiple camera inputs provide increased versatility for use in a wide variety of imaging applications, which make up a substantial portion all Jetson applications today. As with all Diamond products, Floyd is designed and built for reliable performance and extended operating temperature to meet the full capabilities of the Jetson modules. /p>

With the Xavier NX module installed, Floyd offers 1 CAN 2.0B port. The standard configuration is non-isolated; isolation is available as special order.

Floyd is supported by a full Linux BSP based on Nvidia Jetpack. This software is available as a free download from our support area.

◆ Complete System

Floyd is available as a complete system, with the Nano / NX module installed and preprogrammed with Diamond's customized Linux OS for Jetson, all assembled into a sturdy steel and aluminum enclosure. The enclosure provides expansion options for 2 additional DB9 connectors (serial port, GPIO, and/or CAN) as well as up to two SMA type antenna connectors for an installed M.2 or Minicard module. To learn more about these systems [click here](#).



◆ Product Configurations

Floyd is available in two configurations: FLD-BB01 offers the complete suite of I/O features, while FLD-BB02 targets lower-cost applications requiring less I/O. The BB02 model also omits the PCIe switch needed for the BB01 additional I/O, thereby enabling a full PCIe x4 link to the M.2 socket for potentially higher flash memory read/write speeds.

Feature	FLD-BB01	FLD-BB02
Gigabit Ethernet	2	1
PoE	Both ports	No
HDMI	2	1
Camera CSI 4-lane	3	3
USB 3.0	1	1

USB 2.0	2	2
M.2 2280 socket	PCIe x1	PCIe x4
Minicard socket	Full size PCIe + USB	No
SD card	Yes	Yes
GPIO 3.3V	8	8
Serial	2x RS-232/422/485	1x RS-232 1x RS-232/485
CAN 2.0	1 (NX only)	No

◆ FLOYD Block Diagrams

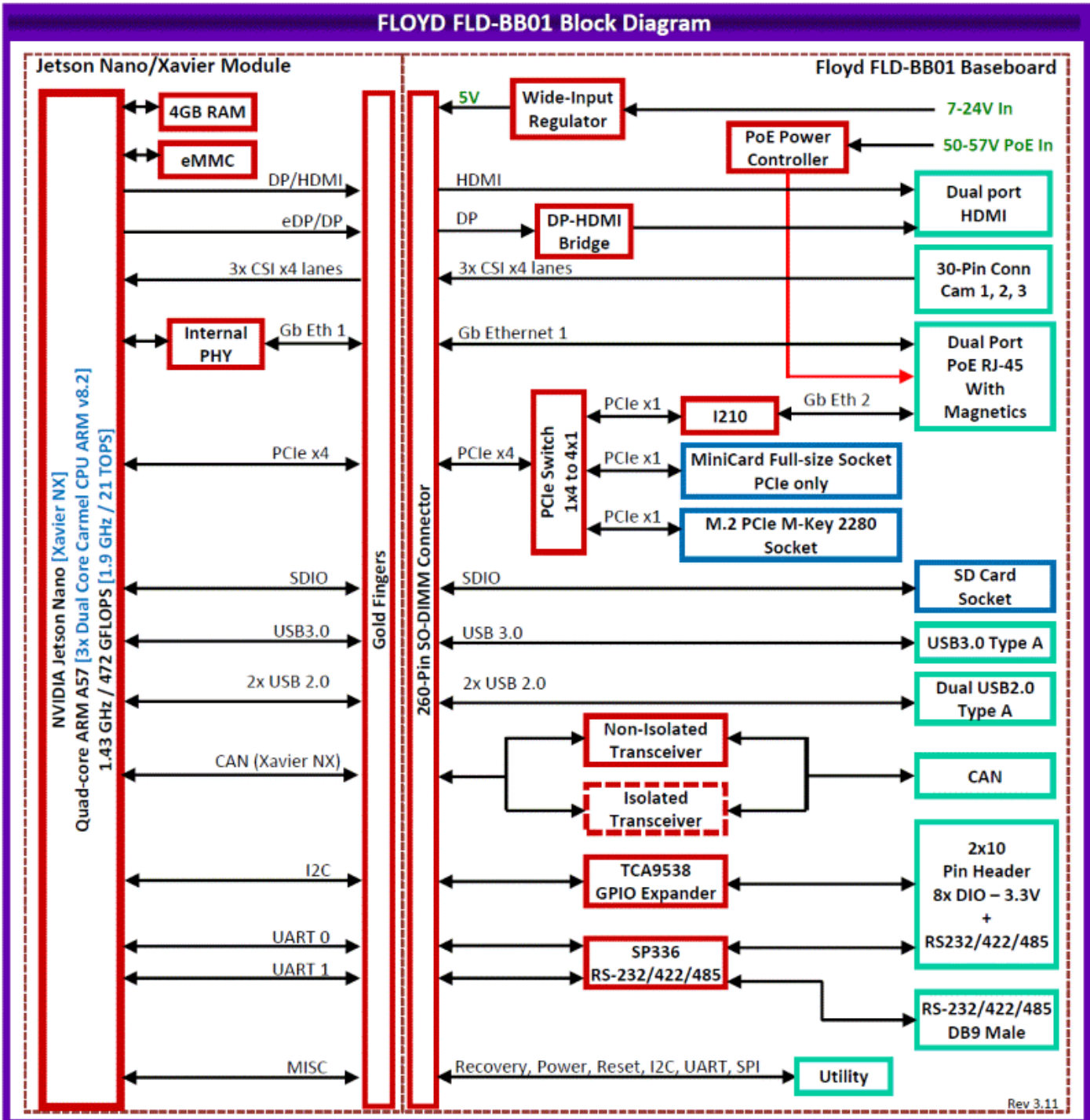

FLOYD FLD-BB02 Block Diagram

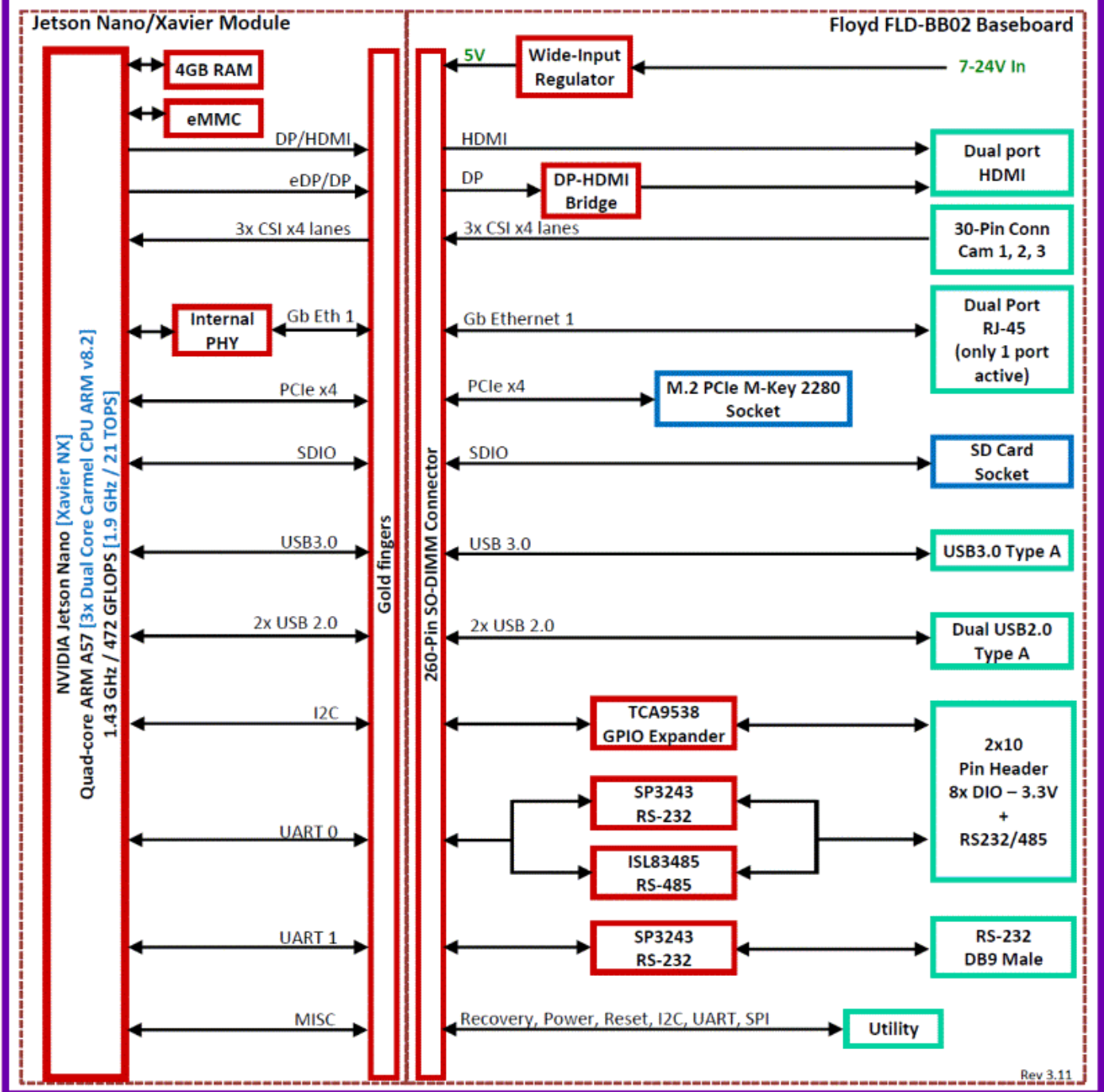

◆ Floyd Features

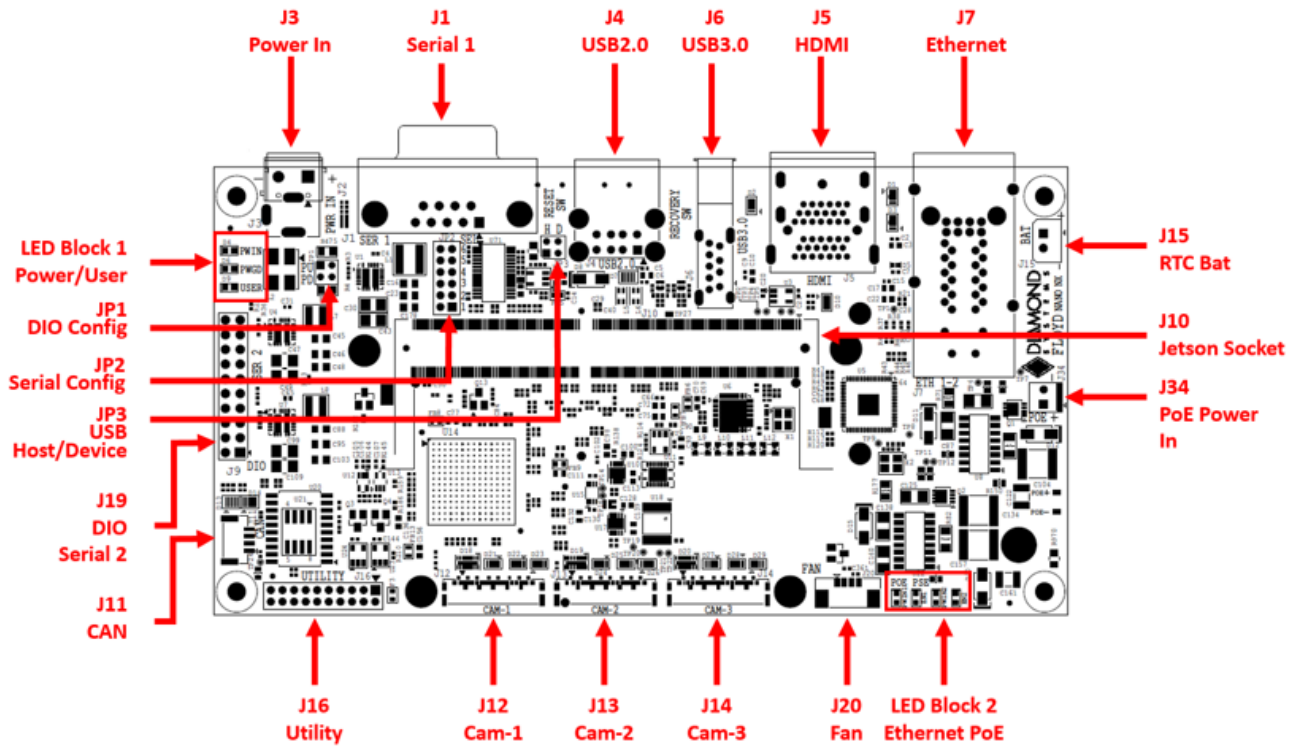

Note: Mini PCIe and M.2 2280 sockets are located on the bottom side.

◆ Cables

Most Floyd I/O other than the camera inputs is available using commercial connectors located along the front edge of the board. This arrangement simplifies the design of enclosures. The second serial port, GPIO signals, and CAN port (available with NX module only) do require cables.

Cable	Description	Drawing
6981182	CANbus 2.0 dual port cable	Show
C-DB9M-2	Serial port cable, 2x DB9M to 2x10 .1" socket	Show

◆ Models and Accessories

FLOYD Carrier for Nano & Xavier NX

available models:

FLD-BB01	FLOYD carrier board for Jetson Nano and Jetson Xavier NX module
FLD-BB02	Floyd baseboard, low-cost model with reduced I/O
JB-FLD-BASE-01	Jetbox Floyd kit, based on BB01 baseboard; includes all items except Nano / NX module and software
JB-FLD-BASE-02	Jetbox Floyd kit, based on BB02 baseboard; includes all items except Nano / NX module and software

Please login or signup for an online quote request.

Cables and accessories

available models:

6981182	CANbus 2.0 dual port cable
C-DB9M-2	Serial port cable, 2x DB9M to 2x10 .1" socket

Please login or signup for an online quote request.