

## EnsembleSeries™ HDS6605

6U OpenVPX Scalable Xeon-SP (Cascade Lake) processing blade

- Intel® 1.9GHz, 22-core Xeon® SP (Cascade Lake) server-class processor
- 96GB-192GB DDR4-2666 SDRAM per module
- 40Gb/s - 100Gb/s Ethernet high speed switch fabrics
- Gen3 PCIe co-processing and I/O expansion plane communications
- Optional MOTS+ rugged packaging for extreme environmental protection
- SOSA compatible profiles

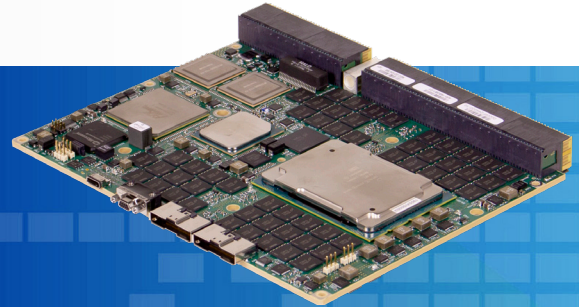

The EnsembleSeries™ HDS6605 is Mercury's fifth generation Intel Xeon-SP server-class, OpenVPXTM processing blade. Leveraging Intel's modern Xeon-SP CPU, Cascade Lake microarchitecture and the support of unrestricted 40Gb/s – 100Gb/s Ethernet fabric bandwidth deliver ultra-scalable general purpose processing performance. Proven mechanical ruggedness and the highly efficient thermal management technology inherent in Mercury's High Density Server product line ensure high product MTBFs even under full throttle, continuous processing conditions.

### Optional MOTS+

The EnsembleSeries HDS6605 family of blades are OpenVPX compliant and have options for modified off the shelf plus (MOTS+) manufacturing and packaging for extreme durability. MOTS+ configurations leverage enhanced commercial components, board fabrication rules, and subsystem design techniques for extra durability and withstand extreme temperature cycles better than other rugged designs.

Mercury's Xeon server-class OpenVPX ecosystem is the most powerful open system architecture (OSA) available for embedded general processing applications, enabling true on-platform cloud processing capability at the tactical edge. The processing power of

these blades is suited to next generation radar, electro-optical/infrared (EO/IR) and complex image intelligence (IMINT), artificial intelligence (AI), machine learning (ML), deep learning (DL) and converged sensor applications. These 1-inch pitch, 6U high OpenVPX blades enable compute capabilities that were never previously possible, adding new functionality and autonomy to modern missions.

EnsembleSeries HDS6605 blades are interoperable with Mercury's large ecosystem of OpenVPX building blocks that includes other Intel Xeon processor solutions, high-speed Ethernet and PCIe switches, and intelligent mezzanine carrier boards. Driven by Mercury's investment in open architecture, harmonized with a focus on backwards compatibility, these scalable open architecture building blocks can be integrated and qualified into a diverse set of deployable signal processing chassis solutions to meet the most challenging sensor and mission processing requirements, for new applications and technology refreshes. For lab development, the same building blocks may be quickly configured into Mercury's standard 6 and 16 slot development chassis.

### SOSA profiles

EnsembleSeries HDS6605 blades are optionally available in Sensor Open Systems Architecture (SOSA) compatible configurations.

*Mercury Systems is a leading commercial provider of secure sensor and safety-critical processing subsystems. Optimized for customer and mission success, Mercury's solutions power a wide variety of critical defense and intelligence programs.*



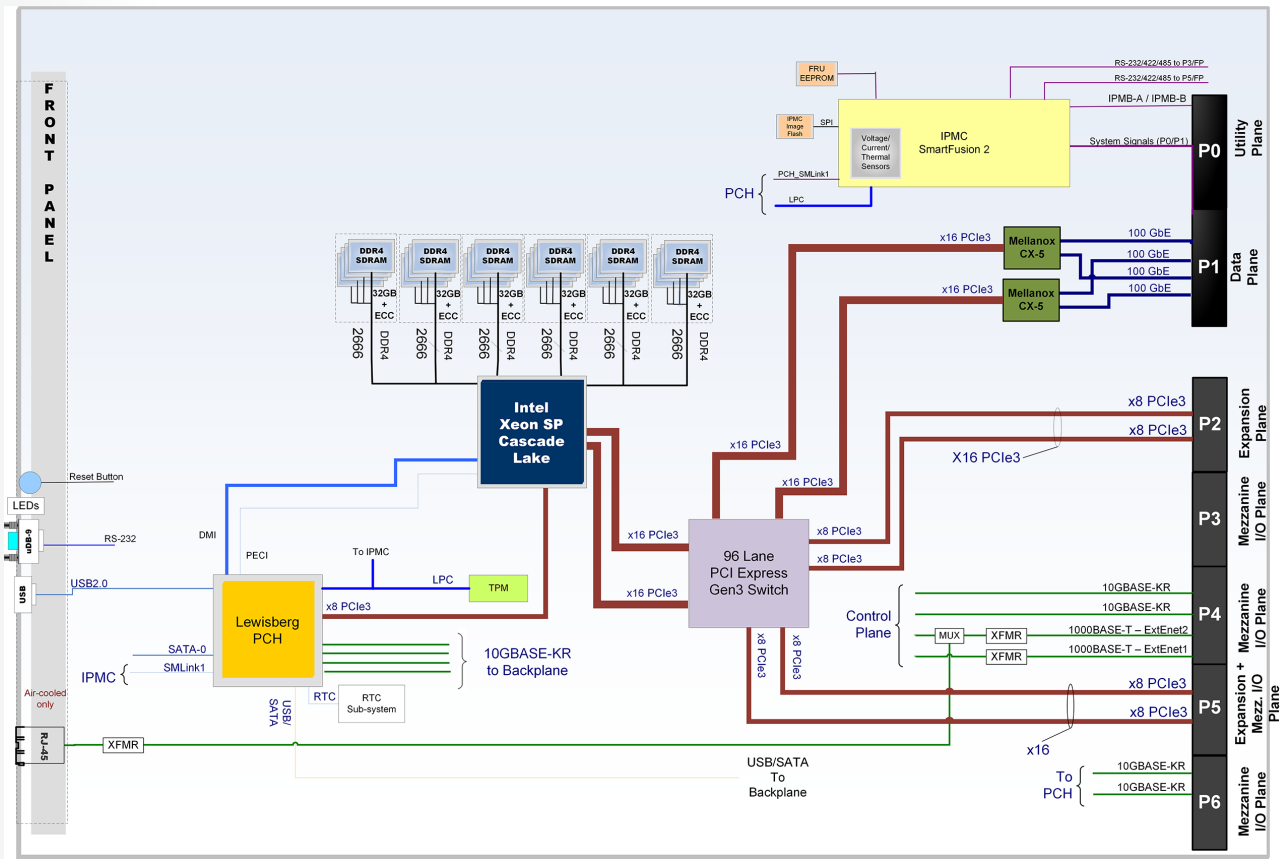

HDS6605 functional block diagram

## Xeon Server-Class Ecosystem

The EnsembleSeries HDS6605 features Intel's 64-bit Xeon-SP 6238T processor (other processor options are also available). This processor is a 3687 pin LGA device, transformed via Mercury robust packaging technologies into a BGA to support a rugged, embedded, and deployable form-factor. This high core count processor architecture is optimized for the data sharing needed by high performance processing algorithms, such as all-to-all corner turn operations and AI applications.

The Xeon-SP 6238T processor delivers 2.68 TFLOPS (peak theoretical), with six high-speed DDR4-2666 memory channels is capable of 111 GT/sec raw memory bandwidth. The EnsembleSeries HDS6605 refines the memory fabrication approach used on the HDS6603B generation of Xeon blades to support 96GB-192GB of on-board DRAM. Native Gen3 PCIe links the processing resources directly to the I/O sources on the blade. EnsembleSeries HDS6605 blades makes use of the Lewisburg platform controller hub (PCH) chipset, which provides additional I/O bridging between the Intel processor and external devices.

The Xeon-SP 6238T processor includes a rebalanced cache architecture, with a 30.25 MB shared non-inclusive L3 cache and a 1MB private L2 cache per core, enabling many high performance calculations to remain cache resident. This accelerates processing by eliminating the potential latency required to access DRAM to fetch upcoming data. The Cascade Lake family of processors also supports the latest AVX512 instruction set, delivering a substantial boost to floating-point algorithm performance that is portable to future Intel

architectures. Each core has two AVX512 fused multiply add (FMA) vector engines, which are especially applicable to radar and similar processing applications which routinely require the summing of vast arrays of multiplied numbers. The inclusion of doubled FMA enables complex radar and similar operations to be performed about twice as quickly as before. Fast Fourier transformations (FFTs) and other matrix manipulations are also handled more efficiently with Intel's server-class memory and processing optimizations inherent in the Xeon-SP processor family versus other Intel Xeon processor families.

## High Speed Fabric Interfaces

EnsembleSeries HDS6605 blades deliver the highest performance data movement in the OpenVPX form-factor. Bridging between the native Gen3 PCIe interfaces on the Intel processors and the OpenVPX data plane, Mellanox's ConnectX-5 can be configured to support 40 or 100 Gigabit Ethernet as the data protocol. This advancement scales the data plane bandwidth to up to a peak theoretical rate of up to 12.5 GB/s per port, or 50 GB/s aggregate across the entire four-port OpenVPX data plane. By scaling the data plane bandwidth to match the increase in processing performance, the HDS6605 architecture ensures that the processor is never starved for data.

HDS6605 blades are compliant to the VITA 65 module profile MOD6-PAY-4F1Q2U2T-12.2.1-n, where 'n' can vary based on ConnectX-5 configuration. The HDS6605 is supported in chassis slots compliant with VITA 65 slot profile SLT6-PAY-4F1Q2U2T-10.2.1, continuing Mercury's support for OpenVPX-driven technology refreshes.

## PCIe Architecture

EnsembleSeries HDS6605 blades provide high-end Gen3 PCIe backplane interfaces via the native PCIe resources on the Intel Xeon SP processor. In addition to supporting the processor's interface to the ConnectX-5 bridges described above, an additional x16 Gen3 PCIe interface is provided to the OpenVPX expansion plane interface on both the P2 and P5 VPX connectors via the on-board 96-lane PCIe switch. These interfaces enable the HDS6605's compatibility with Mercury's GPU, FPGA and mezzanine carrier modules. The interfaces are user configurable to lower port widths and can support non-transparent (NT) bridge functionality at run time. These configuration options support the construction of complex PCIe trees with many other PCIe-capable devices.

## System Management Plane

Each HDS6605 blade implements the advanced system management functionality architected in the OpenVPX standard to enable remote monitoring, alarm management, and hardware revision and health status.

Using the standard I2C bus, intelligent platform management controller (IPMC), and IPMI protocol, the on board system-management block implementation is designed to comply with VITA 46.11. This allows each EnsembleSeries HDS6605 blade to:

- Read sensor values
- Read and write sensor thresholds, allowing an application to react to thermal, voltage, or current variations that exceed those thresholds
- Reset the entire blade
- Power up/down the entire blade
- Retrieve blade field replaceable unit (FRU) information
- Be managed remotely by a chassis management controller at the system level

## Additional Features

The EnsembleSeries HDS6605 blade provides all the features typically found on a single-board computer. In addition to the sophisticated management subsystem and fabric interconnect, each HDS6605 blade provides users with a toolkit enabling many different application features including:

- Dual 10GBASE-KR Ethernet interfaces, in addition to dual 10GBASE-KR control plane interfaces
- Dual 1000BASE-T external Ethernet interfaces
- Backplane USB and SATA interfaces for alternate boot or storage paths
- Thermal and voltage sensors integrated on-board
- Real-time clock with accuracy better than 10ppm<1second per day
- General purpose timers
- Global clock synchronization capabilities via the OpenVPX utility plane clock signals
- Watchdog timer to support interrupt or reset
- Multiple boot paths, include netboot, USB boot, boot from SATA, or from the on-board flash device

## Open Software Environment

Mercury leverages over 35 years of multicomputing software expertise, including recent multicore processor expertise, across its many platforms. This strategy is fully applied to the HDS6605 blade. The same Linux® development and run-time environment is implemented on the HDS6605 blade as on other Intel based Mercury OpenVPX modules across the Ensemble 3000 and 6000 Series. Off-the-shelf open software such as OFED and OpenMPI are fully supported by the Mellanox ConnectX-5 data plane.

## Mercury's OpenVPX Ecosystem

Sensor processing chain awareness, building blocks and ecosystem  
Sensor chain awareness is having the technical expertise and resources to design and build capable, compatible solutions along the whole sensor processor chain. From RF, digital/analog signal manipulation to dense, SWaP optimized processing resources to actionable intelligence dissemination; Mercury's rugged processing subassemblies leverage the best commercial-item technology, enabling prime contractors to win more business.

Modern sensor processing subassemblies are customized assemblies of interoperable building blocks built to open standard architectures. Mercury's hardware and software portfolio of building blocks are physically and electrically interoperable as defined by international industrial standards, including OpenVPX.

## System Bandwidth – The Effect of Interconnect Performance

Bandwidth is critical and especially applicable to switched fabric resources that dictate the responsiveness of the entire subsystem. All modular solutions, including OpenVPX are to some degree, interconnect-bound; they are restricted by the limitations of the best industry interconnect technology. To address this, Mercury fabricates system interconnections with innovative technology, which mitigates insertion-loss and cross-talk while maintaining full VITA/ OpenVPX compliance. The resulting system performance boost enables the latest fabrics to run at full, unencumbered speed.

### VPX-REDI

The VPX (VITA 46) standard defines 6U and 3U board formats with high performance interconnects capable of supporting today's high-speed fabric interfaces. VPX may be paired with the ruggedized enhanced design implementation standard — REDI (VITA 48). HDS6605 blades when implemented as conduction-cooled, Air Flow-By™, or Liquid-Flow-Through are VPX-REDI compatible. Air-cooled equivalents conform to the same OpenVPX form-factor and are suitable for less challenging environments. Targeted for harsh embedded environments, VPX-REDI supports higher functional density and two-level maintenance (2LM). 2LM enabling relatively easy module replacement.

### Rugged Liquid-Flow-Through

Many OpenVPX subsystems are deployed into platforms or environments where air is not available for cooling. For these environments, where liquid is available, the use of open standard Liquid-Flow-Through cooling offers an elegant thermal management solution. Liquid-Flow-Through (VITA 48.4) has grown in popularity, although to be truly effective and reliable, especially for drip protection its implementation requires a true systems engineering approach. Mercury has invested significantly in the application of Liquid-Flow-Through technology to modules and pre-integrated chassis solutions, and successfully deployed this technology to multiple customers and use cases. The HDS6605 is one of many Mercury compute solutions that are built ready for the use of Liquid-Flow-Through cooling.

### Rugged Air Flow-By

Air- and conduction-cooled subsystems rely on filtration to remove contaminants from their cooling air streams. Mercury's Air Flow-By technology eliminates filtration with the most elegant cooling solution available within a sealed and rugged package. Fully compliant to the VITA 48.7 standard, Air Flow-By maintains OpenVPX's 1-inch pitch requirement, is highly resilient to liquid and particle contamination, boosts SWaP, reduces operating temperature, extends MTBF by an order of magnitude and enables embedded deployment of the most powerful and reliable processing solutions. HDS6605 blades are available as air-cooled (various levels of ruggedness), and rugged Air Flow-By, Liquid-Flow-Through, and conduction-cooled variants.

## Specifications

### Processor

Intel Xeon SP 6238T 1.9GHz 22-core server-class processor

Peak performance 2.68 TFLOPS per blade

Threads per core 2

Dual Integrated x16 Gen3 PCIe interface

### Memory

Up to 192 GB DDR4-2666 with ECC

### BIOS

SPI flash: Dual 8 MB partitions

NAND flash: 16 GB, SATA interface

### Data Plane PCIe to Switched Fabric Bridge

Mellanox ConnectX-5 10/40/100 Gigabit Ethernet host adapter

### Ethernet Connections

Ethernet functions supported by the chipset include:

UDP, TCP, SCTP, ARP, IPv4, IPv6, IEEE1588, flow control, 802.1P (priority) and 802.1Q (VLAN)

### IPMI (Intelligent Platform Management Interface)

On-board IPMI controller

Voltage and temperature monitor

Geographical address monitor

Power/reset control

FRU and on-board EEPROM interfaces

FPGA, CPU, and CPLD interfaces

### OpenVPX Multi-Plane Architecture

System Management via IPMB-A and IPMB-B link on P0 management plane

40/100 Gigabit Ethernet interfaces on data plane

10 Gigabit Ethernet interfaces on control plane

Dual full x16 or dual-dual x8 PCIe Gen3 expansion plane

### Mechanical

6U OpenVPX

1.0" slot pitch for all packages OpenVPX and VPX REDI

Power consumption:

~200W per blade (estimate; based on customer application performance)

### Standard Compliance

OpenVPX System Standard (VITA 65) encompasses:

VITA 46.0, 46.3, 46.4, 46.6, 46.11, and VITA 48.1, 48.2, 48.4, 48.7 (REDI)

VITA 65 module profiles

SLT6-PAY-4F2Q1H4U1T1S1TU2U2T1H-10.6.4-n (SOSA compatible)

MOD6-PAY-4F1Q2U2T-12.2.1-n (where n can vary based on ConnectX-5 configuration)

Dual 10GBASE-KR Ethernet control plane

Please refer to Mercury publication "Rugged Embedded Packaging and Next Generation Cooling" for specific ruggedness levels and cooling options.

Mercury Systems – Innovation That Matters®

Mercury Systems is the leader in making trusted, secure mission-critical technologies profoundly more accessible to the aerospace and defense industries. Optimized for customer and mission success, our innovative solutions power more than 300 critical aerospace and defense programs. Headquartered in Andover, Mass., and with manufacturing and design facilities around the world, Mercury specializes in engineering, adapting and manufacturing new solutions purpose-built to meet the industry's current and emerging high-tech needs. Our employees are committed to Innovation that Matters®. To learn more, visit [mrcy.com](http://mrcy.com), or follow us on Twitter.

Copyright © 2020 Mercury Systems, Inc.

3489.05E-0820-ds-HDS6605



**INNOVATION THAT MATTERS®**

**CORPORATE HEADQUARTERS**

50 Minuteman Road • Andover, MA 01810 USA  
(978) 967-1401 • (866) 627-6951 • Fax (978) 256-3599

**EUROPE MERCURY SYSTEMS, LTD**

Unit 1 - Easter Park, Benyon Road, Silchester, Reading  
RG7 2PQ United Kingdom  
+ 44 0 1189 702050 • Fax + 44 0 1189 702321