

Current Probes from PPM Test

Current probes from PPM, manufactured by Prodyn, are available with a variety of designs: hinged and non-hinged, axial or radial output as well as various bandwidths, transfer impedances, aperture sizes and current ratings. Non-standard connectors and load impedances are available on request.



CIP-100/500/500HE

The CIP series are high performance wideband devices which measure current inside a 50Ω coaxial cable. Connector types other than SM can be supplied on request.

	CIP-100	CIP-500	CIP-500HF
Bandwidth (3 dB points)	20kHz to 200MHz	100kHz to 200MHz	140kHz to 800MHz
Transfer Impedance	1Ω	5 Ω	5 Ω
Bandpass Flatness (±0.5dB)	50kHz to 100MHz	30kHz to 100MHz	150kHz to 700MHz
Current Handling Capability	1A rms (CW)	1A rms (CW)	1A rms (CW)
Maximum Pulse Input	25A μsec	5A μsec	5A μsec
Connector	SMA (female)	SMA (female)	SMA (female)
Output Load Impedance	50Ω	50Ω	50Ω

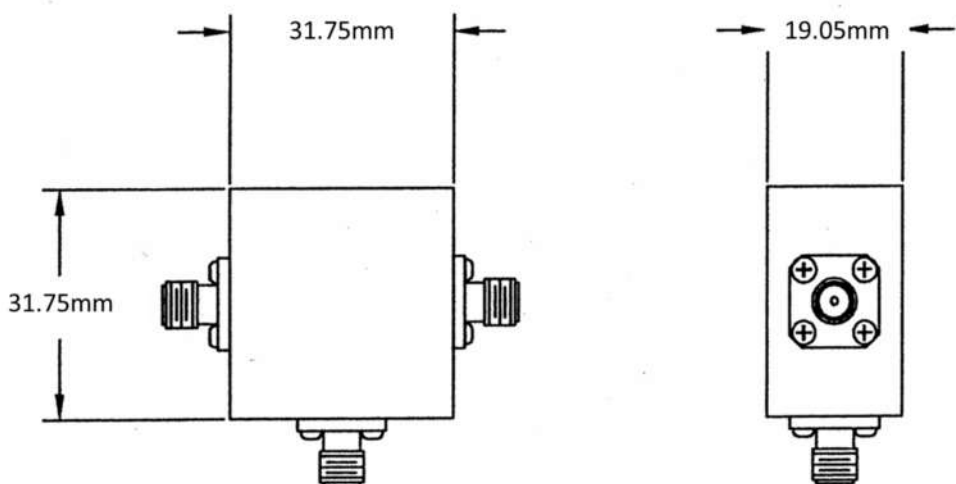

IP-10/50

The IP-10 and IP50 are small wideband current probes developed to test current on small diameter conductors that can be inserted through the aperture. Both probes feature an SMC jack as standard. Other connectors and transfer impedances are available.

	IP-10	IP-50
Bandwidth (3 db points)	20kHz to 400MHz	300 KHz to 400 MHz
Transfer Impedance	1Ω	5Ω
Bandpass Flatness (±.5 db)	100kHz to 100MHz	1 KHz to 100 MHz
Current Handling Capability (CW)	1A rms	1A rms
Maximum Pulse Input	1A ms	1A ms
Connector	SMC Jack	SMC Jack

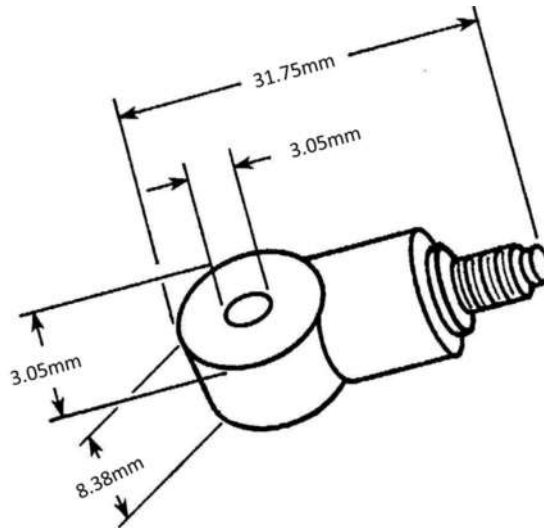

I-125 KWIK LATCH® CURRENT PROBE

Prodyn's KWIK LATCH® current probes are wideband devices designed to measure current on cable bundles and other RF sources without having to disconnect the conductor. The probes have a durable, hinged, two-piece design with a mid-sized aperture. The I-125 series have a 50Ω output load impedance and come with an 'N' type connector as standard. Other connector types are available.

Model	Zt (Ω)	Usable Frequency Range	3 dB Points
I-125-1A	5	10kHz to 100MHz	110kHz to 90 MHz
I-125-1D	5	1kHz to 110MHz	25kHz to 80 MHz
I-125-1E	5	850 Hz to 120MHz	5kHz to 70MHz
I-125-1 HF	5	50kHz to > 1GHz	120kHz to >600MHz
I-125-2A	1	10kHz to 150MHz	30 KHz to 80MHz
I-125-2C	1	300 Hz to 25MHz	600 Hz to 10MHz
I-125-2 HF	1	50kHz to > 1GHz	80kHz to >500MHz
I-125-7A	1	400 Hz to 100MHz	540Hz to 30MHz
I-125-6A	0.5	20 Hz to 30MHz	60Hz to 10MHz
I-125-4A	0.1	1kHz to 150MHz	4kHz to 110MHz
I-125-3A	0.03	1kHz to 250MHz	10kHz to 180MHz
I-125-9A	0.005	1kHz to 270 MHz	10kHz to 200 MHz

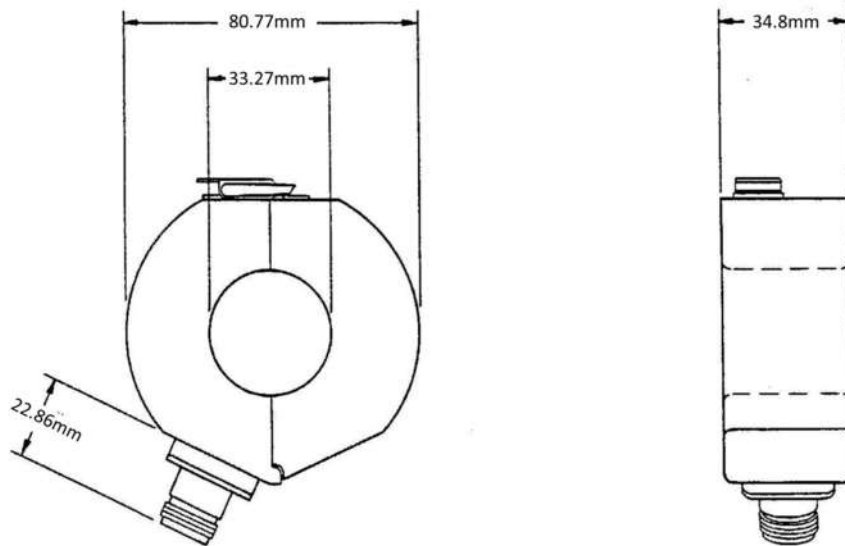

I-262 KWIK-LATCH® CURRENT PROBE

Prodyn's KWIK LATCH® current probes are wideband devices designed to measure current on cable bundles and other RF sources without having to disconnect the conductor. The probes have a durable, hinged, two-piece design with a mid-sized aperture. The I-125 series have a 50 Ω output load impedance and come with a female 'N' type connector as standard. Other connector types are available.

MODEL	Zt (Ω)	FREQUENCY RANGE
I-262-2A	5	10 kHz to 50 MHz
I-262-3A	2	10 kHz to 140 MHz
I-262-4A	0.06	10 kHz to 100 MHz
I-262-5A	1	10 kHz to 200 MHz
I-262-6B	0.1	10 kHz to 150 MHz

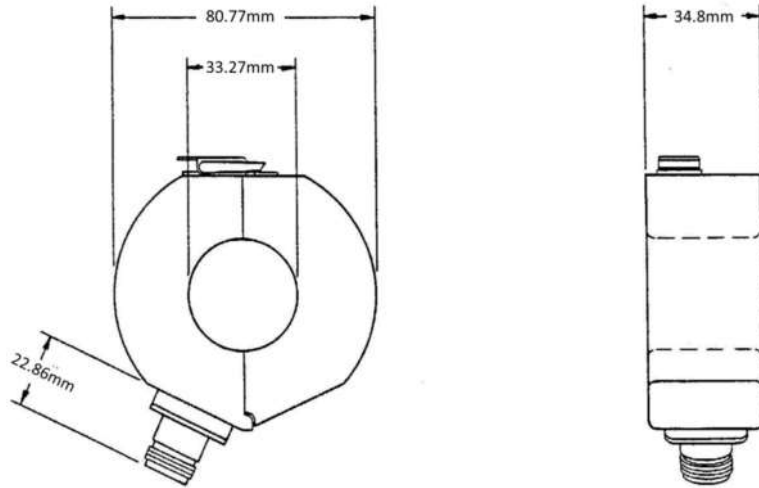

MODEL I-210A AND I-210B (RADIATION-HARDENED)

The I210A and B sensors are clamp-on, radiation-hardened current transformers. The sensors are designed to measure the current on large cable bundles. The differential output voltage is an accurate representation of the total current flowing though the central aperture - subject to bandwidth limitations of the sensor.

The equation relating sensed current and differential output voltage is:

$$V_{out} = R_T \times I_{sensed}$$

...where R_T = transfer impedance.

The sensors are split to allow clamping the device onto a cable, cable bundle or structural member that fits the central aperture. The presence of the sensor adds a series impedance to the sensed current carrier - referred to as the *insertion impedance*.

	I-210A	I-210B
Transfer Impedance	0.125Ω	0.131Ω
Frequency Response (3 dB)	100Hz – 4MHz	70Hz – 2.5MHz
Current Range of Measurement	10 – 100A	10 – 100A
Core Material	metal tape	metal tape
Output Connector	100Ω differential twinax, amphenol 22950 or equivalent	100Ω differential twinax, amphenol 22950 or equivalent
Aperture	304.8mm dia	304.8mm dia

N.B. Other connector types are available

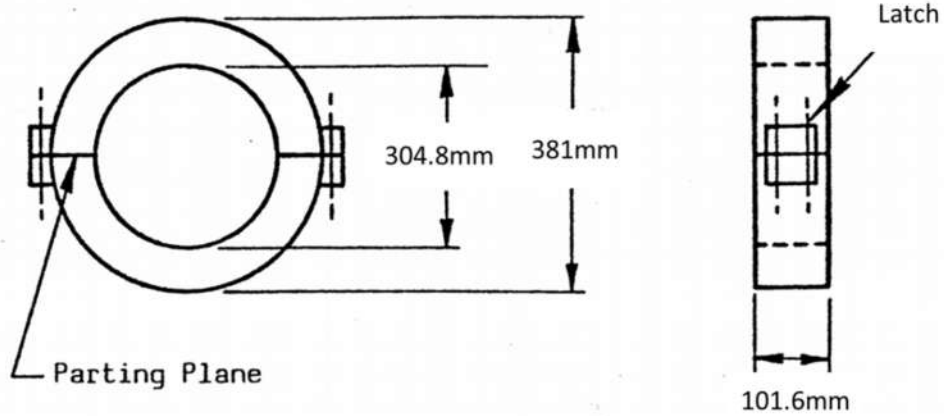

I-300/310/320 SPRING CLAMP-ON CURRENT SENSOR

The I300 series wideband current probes are designed to facilitate current measurements on conductors where space is limited. The convenient size and shape make them quick to install over existing conductors that are inconvenient to pass through a fixed-window type probe. The 5.59mm aperture allows testing of cables with a maximum size of RG-58.

	I-300	I-310	I-320
Frequency Range (3dB pts)	180kHz to 300MHz	50kHz to 200MHz	200kHz to 500MHz
Bandpass (+ 0.5dB)	400kHz to 200MHz	100kHz to 125MHz	150kHz to 450MHz(<2dB)
Transfer Impedance ZT	5	1	1
Current Handling Capability	>10 A pulse	>10 A pulse	>10 A pulse
Output Impedance	50Ω	50Ω	50Ω
Connector	SMA	SMA	SMA

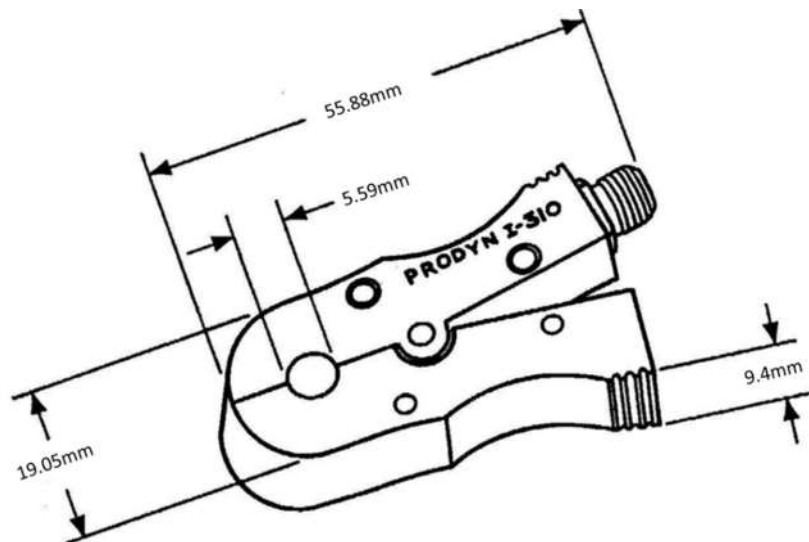

I-400/410 LARGE SPRING CLAMP-ON CURRENT SENSOR

The I400 series of wideband current probes are designed to facilitate current measurements on conductors where space is limited. The convenient size and shape make them quick to install over existing conductors that are inconvenient to pass through a fixed-window type probe. The aperture allows testing of cables with a maximum size of RG-9. The equation relating sensed current and differential output voltage is:

$$V_{out} = Z_T \times I_{sensed}$$

...where Z_T = transfer impedance.

	I-400	I-410
Frequency Range (3db points)	50 kHz to >450 MHz	15 kHz to >450 MHz
Bandpass Flatness (+ .5db)	120 kHz to 50 MHz	30 kHz to 200 MHz
Transfer Impedance (Z_T)	5Ω	1Ω
Current Handling Capability	1 amp RMS (CW)	1 amp RMS (CW)
Output Impedance	50Ω	50Ω
Connector	SMA (female)	SMA (female)

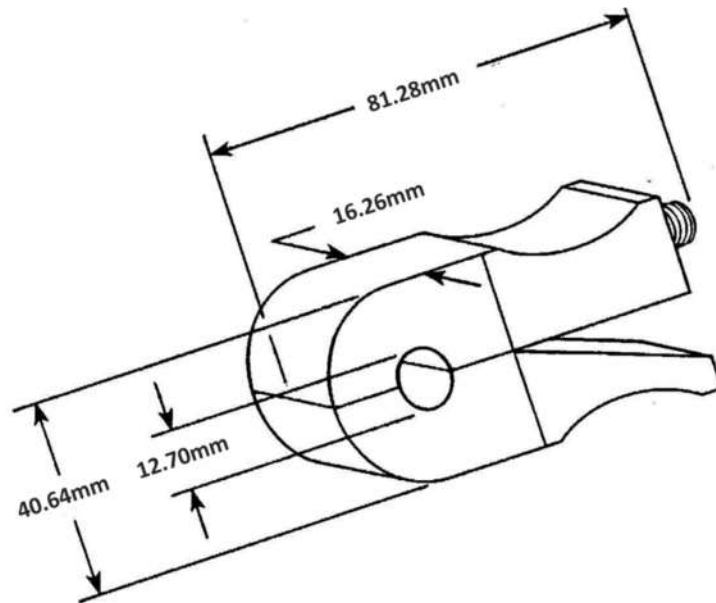

IP2-HF SERIES HIGH FREQUENCY CURRENT SENSOR

The IP series are high frequency sensors used to measure current on small conductors. Their small size minimised the physical constraints of usual measurements and the choice of three sensitivities allows for a variety of outputs. The flat response over a wide band is unparalleled compared with similar sensors. A short single-ended output with an SMA connector is standard but all models can also be ordered with a differential output. Modifications to the output length and connector type are also possible. The equation relating sensed current and differential output voltage is:

$$V_{out} = Z_T \times I_{sensed}$$

...where Z_T = transfer impedance.

	IP-2-1	IP-2-5	IP-2-10
Freq. Range(3db pts):	100kHz-1.3GHz	125kHz-800MHz	500kHz-1GHz
Transfer Impedance (Z_t):	1Ω	5Ω	10Ω
Current Handling Cap.:	0.8 amps (RMS)	0.8 amps (RMS)	0.8 amps (RMS)
Output Impedance:	50Ω	50Ω	50Ω
Standard Connector.:	SMA	SMA	SMA

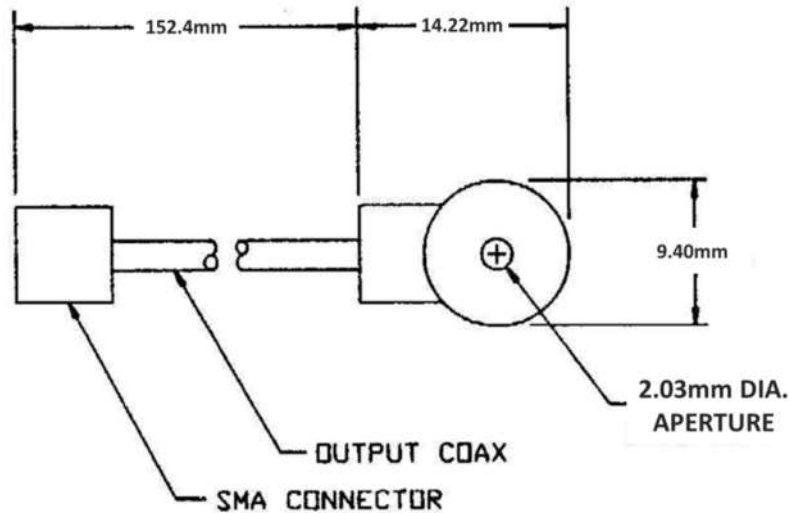

SMALL PROFILE CURRENT TRANSDUCERS

The I-075-1B/C and I-125-1B small profile current sensors were designed to meet the current testing requirement where space is a premium but a maximum aperture is required. These sensors have excellent frequency response characteristics with radial or axial outputs and small overall outside diameters in comparison to aperture size. The KIWK-KLATCH® design affords simple attachment over cables or conductors with having to pass them through the aperture. They can be ordered with SMA, TNC or BNC (female) connectors. Other connector types are available.

	I-075-1B	I-075-1C	I-125-1B
Frequency Range (3dB pts)	70kHz to 130MHz	218kHz to 340MHz	90kHz to 110MHz
Usable Freq. Range	40kHz to 150MHz	120kHz to 150MHz	50kHz to 130MHz
Transfer Impedance (Z_t)	5Ω	5Ω	5Ω
Saturation Limit (Pulse)	50A	30A	70A
Output Load Impedance	50Ω	50Ω	50Ω

The new Prodyn I-075N-10 is a small profile current probe with a reduced height, compared to model series I-075-1B and C. It has increased sensitivity with a transfer impedance of approximately 10Ω, allowing transmission at a lower power level for a clean signal. The model also has a split design that can be clamped over cables or conductors to be measured and a radial output direction for easy connection. The I-075N-10's small size allows it to be easily fitted into modern regional jet or military aircraft bays for testing.

	I-075N-10
Frequency Range	160 KHz to 350 MHz
Transfer Impedance	10 Ω
Peak Current	200A
CW Current	15.4A
Saturation Current	13.7A

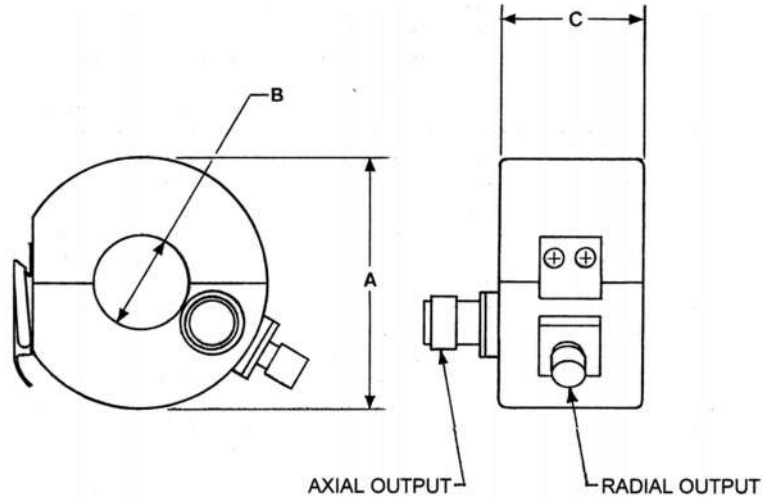

	A	B	C
I-075-1B & C	50.04mm	19.05mm	28.45mm
I-125-1B	63.50mm	31.75mm	35.56mm

Radial or axial output should be specified at the time of order